

## ARCHITECTURAL SYMBOLS

The drawing of an architectural working drawing requires a knowledge of the symbols and terms commonly used in the design and construction industry. All architectural working drawings must communicate in a clear and concise manner to the builders.

In order to simplify the details on a drawing and to speed drawing time it is necessary to use architectural symbols. Many symbols are designed to approximate the appearance of an item, or the material from which it is constructed (Fig. 1 ). Some symbols however, may have no graphic resemblance to the material or item that they are to represent (fig. 2 ).

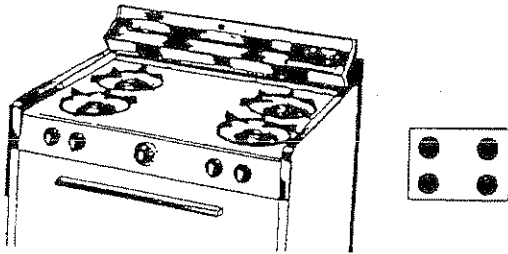

Fig. 1 Some architectural symbols are similar to the item they represent

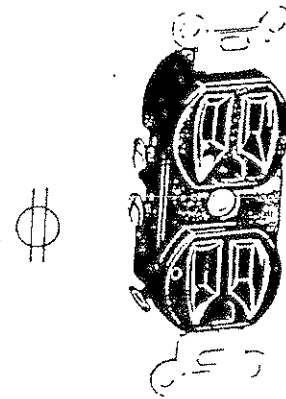

Fig. 2 Some architectural symbols have no similarity to the item they represent

### SYMBOL CONVENTIONS

The American Institute of Architect (AIA) and the American National Standard Institute (ANSI) have each set standard conventions for architectural symbols. Since many new and different types of construction materials, appliances and fixtures are continually being developed and used in construction, many architectural drafters will use symbols of their own design and show their meaning in a legend or symbol chart on the drawing. While there are some different symbols being used, there is an overall acceptance of the AIA and ANSI symbol conventions.

As a general rule when a symbol is not clear or a new type of material is to be noted on a drawing, a notation should be used with the symbol (Fig. 3 ). This will clarify the communication to the builders. It must be remembered that architectural working drawings must be read by many persons in the building trades. Everything must be clear so no guess work will be involved with the design, ordering of materials or construction phases.

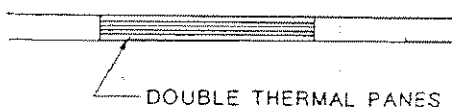

Fig. 3 For clarity, if it is needed, use a notation with the symbol

## RULES FOR DRAWING SYMBOLS

1. Always use drawing instruments. Never draw the symbols freehand on a working drawing. Use an architectural drawing template to increase the speed and clarity of the symbols (Fig. 4 ). Be certain that the template figures are the same scale as your drawing's scale.

2. The location of the symbol on the working drawing is closely approximated. If an exact location is required, dimensions must be added to the symbol on the drawing (Fig. 5 ).

3. Symbols are not drawn to the exact size of the actual item. The general size of the architectural symbols will vary with the scale of the drawing. The symbol should be of convenient reading size. It should not be too small or large (Fig. 6 ).

4. Material symbols need not cover the full surface as shown in figure 7 .  
Repetitious drawing symbols need not be completely drawn.

5. Have references for architectural symbols available.

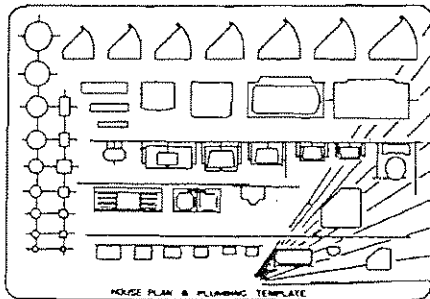

Fig. 4 Use an architectural template for the drawing of symbols

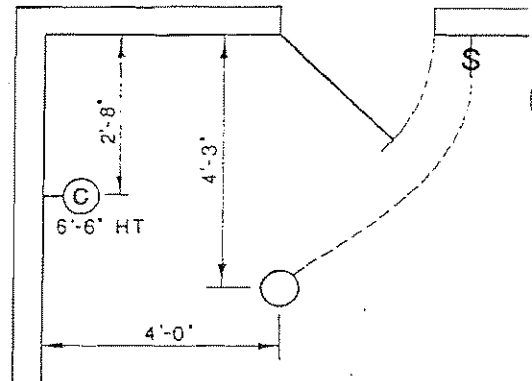

Fig. 5 Add dimensions if exact locations are required

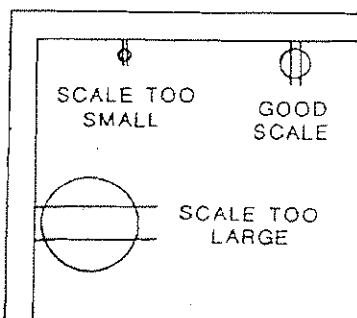

Fig. 6 Good symbol proportions are important for architectural working drawings

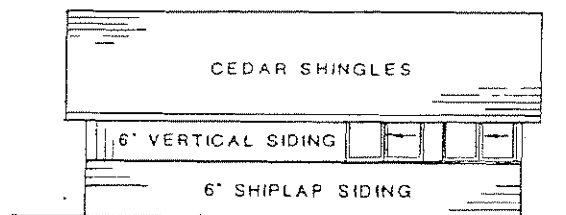
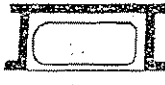



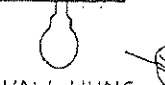
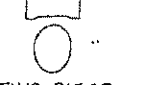

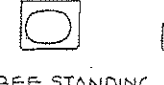

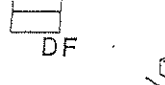
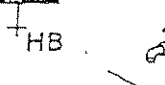
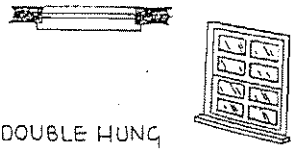
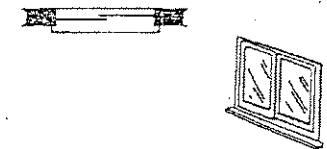
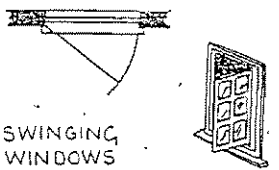
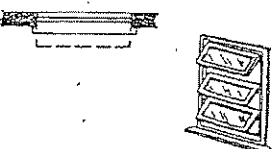
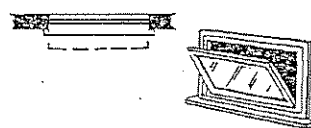
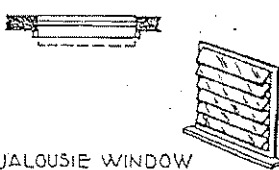
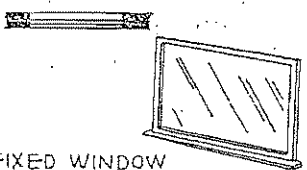
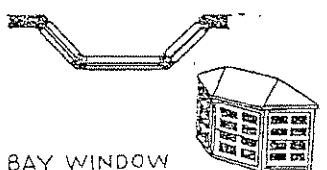
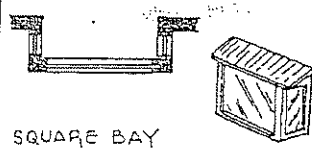

Fig. 7 Symbols for surface cover materials need not cover the entire surface

# PLUMBING SYMBOLS

 RECESSED BATH TUB BT	 FREE STANDING BATH TUB BT	 SQUARE BATH TUB BT
 CORNER BATH TUB BT	 SITZ BATH TUB BT	 ONE PIECE WATER CLOSET WC
 WALL HUNG WATER CLOSET WC	 TWO PIECE WATER CLOSET WC	 WALL HUNG URINAL UR
 SHOWER HEAD SH HD	 BIDET B	 FREE STANDING URINAL UR
 WALL HUNG LAVATORY LAV	 FREE STANDING LAVATORY LAV	 COUNTER TOP LAVATORY LAV
 SHOWER SH	 CORNER SHOWER SH	 CORNER LAVATORY LAV
 DRINKING FOUNTAIN DF	 WATER COOLER WCL	 HOSE BIB WB

# WINDOW SYMBOLS

 DOUBLE HUNG WINDOW DHW	 SLIDING WINDOW SLD WDW	 SWINGING WINDOWS SWG WDW
 AWNING WINDOW AWN WDW	 HOPPER WINDOW HOP WDW	 JALOUSIE WINDOW JAL WDW
 FIXED WINDOW FX WDW	 BAY WINDOW BAY WDW	 SQUARE BAY WINDOW SQ BAY WDW

# DOOR SYMBOLS

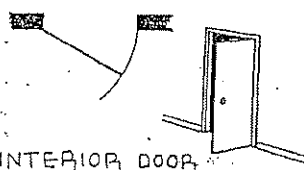
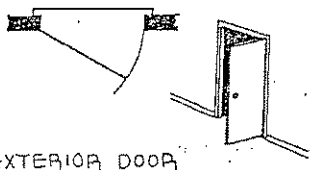
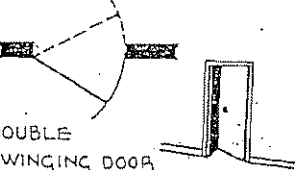
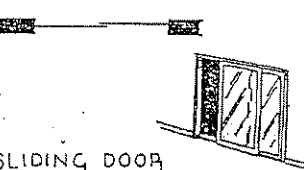
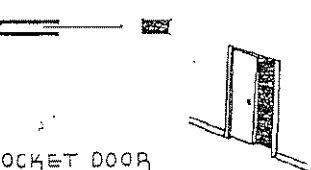
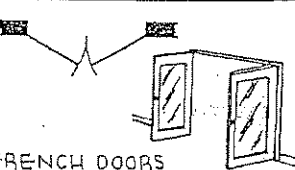
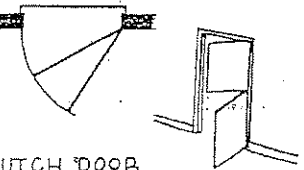
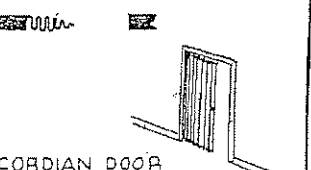
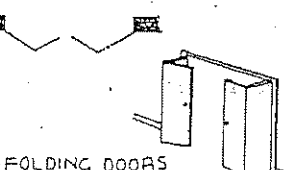
 INTERIOR DOOR INT DR	 EXTERIOR DOOR EXT DR	 DOUBLE SWINGING DOOR OBL SWG DR
 SLIDING DOOR SLDG DR	 POCKET DOOR PK DR	 FRENCH DOORS FR DRs
 DUTCH DOOR DT DR	 ACCORDIAN DOOR ACDN DR	 BI-FOLDING DOORS BI-FLD DRs

# VARIOUS ARCHITECTURAL SYMBOLS

Abbreviation, plan symbol, elevation and pictorial

## BUILDING MATERIAL SYMBOLS:

NAME	ABBREV	SECTION SYMBOL	ELEVATION	NAME	ABBREV	SECTION SYMBOL	ELEVATION	NAME	ABBREV	SECTION SYMBOL	ELEVATION	NAME	ABBREV	SECTION SYMBOL	ELEVATION
COMMON BRICK	COM BRK			WELDED WIRE MESH	WWM			EARTH	E			CUT STONE, ASHLAR	CT STN ASH		
FACE BRICK	FC BRK			FABRIC	FAB			ROCK	RK			CUT STONE, ROUGH	CT STN RGH		
PIREBRICK	FRB			LIQUID	LOD			SAND	SD			MARBLE	MARB		
GLASS	GL			COMPOSITION SHINGLE	COMP SH			GRAVEL	GV			FLAGSTONE	FLG ST		
GLASS BLOCK	GL BLK			RIGID INSULATION SOLID	RIG INS			CINDERS	DIR			CUT SLATE	CT SLT		
STRUCTURAL GLASS	STRUC GL			LOOSE-FILL INSULATION	LF INS			AGGREGATE	AGR			RANDOM RUBBLE	RND RUB		
FROSTED GLASS	FRST GL			QUILT	QLT			CONCRETE	CONC			LIMESTONE	LM ST		
STEEL	STL			SOUND INSULATION	SND INS			CEMENT	CEM			CERAMIC TILE	CER TL		
CAST IRON	CST IR			CORK INSULATION	CRK INS			TERAZZO CONCRETE	TER CONC			TERRA-COTTA TILE	TC TL		
BRASS & BRONZE	BRS BRZ			PLASTER WALL	PLST WL			CONCRETE BLOCK	CONC BLK			STRUCTURAL CLAY TILE	ST CL TL		
ALUMINUM	AL			PLASTER BLOCK	PLST BLK			CAST BLOCK	CST BLK			TILE SMALL SCALE	TL		
SHEET METAL (FLASHING)	SHT MTL FLASH			PLASTER WALL AND METAL LATHE	PLST WL & MT LTH			CINDER BLOCK	CIN BLK			GLAZED FACE HOLLOW TILE	GLZ FAC HOL TL		
REINFORCING STEEL BARS	REBAR			PLASTER WALL AND CHANNEL STUDS	PLST WL & CHN STD			TERRA-COTTA BLOCK LARGE SCALE	TC BLK			TERRA-COTTA BLOCK SMALL SCALE	TC BLK		



ARCHITECTURAL DRAWING  
INFORMATION SHEET

FLOOR-PLAN DIMENSIONING

Dimensions show the builder the width and length of the building. Dimensioning architectural drawings differ from dimensioning mechanical drawings in many ways. The DIMENSIONING system most commonly used in architectural drafting is known as **aligned dimensioning**. With this system, dimensions are placed in line with the dimension lines and are read from the bottom or right side of the sheet. Dimension numerals are centered on and placed above the solid dimension lines:

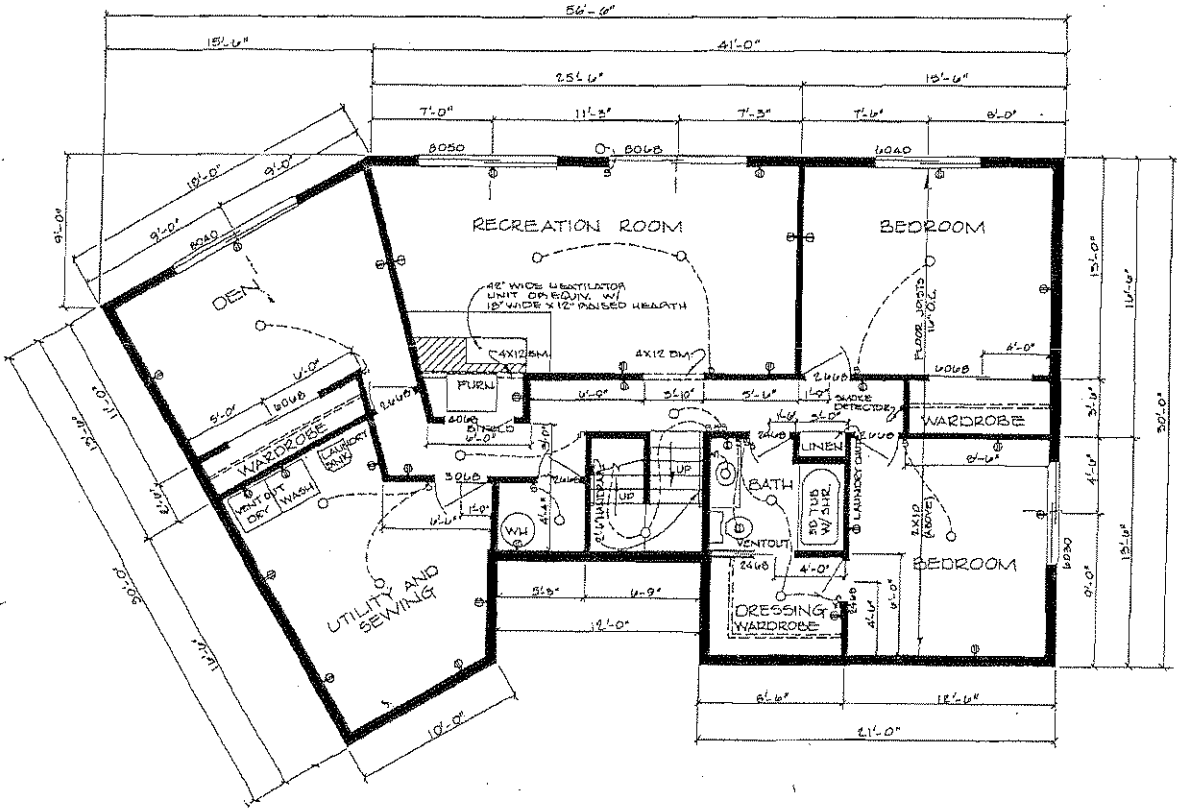

BASEMENT FLOOR PLAN  
SCALE: 1/4" = 1'-0"

1400 SQUARE FEET

ALIGNED DIMENSIONING ON A FLOOR PLAN

# RULES FOR DIMENSIONING

1. Architectural *dimension lines* are unbroken lines with dimensions placed above the line.
2. In drawing plans, feet and inch marks may be omitted as a general rule, (Do not omit dash).
  - a. Dimensions over 1' are expressed in feet and inches.
  - b. Dimensions less than 1' are shown in inches.
3. A slash is often used with fractional dimensions to conserve vertical space.
4. Dimensions should be placed to read from the right or from the bottom of the drawing.
5. You should place dimensions so that the drawing **does not** appear crowded.
  - a. Space dimension lines a minimum of 3/8" from the object and from each other.
  - b. If there is room, it is preferred to start the first dimension line 1/2" from the plan.
6. **Be consistent** so that dimension lines are evenly spaced (regardless of distance chosen).
7. Dimension lines terminate at the extension lines with dots, arrowheads, or slash marks.
8. Dimension numerals are drawn 1/8" high with the aid of guidelines.
9. Line and arrowhead weights are the same as those used in dimensioning mechanical drawings.
10. Overall building dimension are placed outside the other dimension lines.
  - a. The first line of dimensions on the plan is the smallest distance from the exterior wall the the center of windows, doors and partition (interior) walls.
  - b. The second lines of dimensions generally gives the distance from the outside walls to the partition (interior) walls.
  - c. The third line of dimensions is usually the overall distance between the two exterior walls.

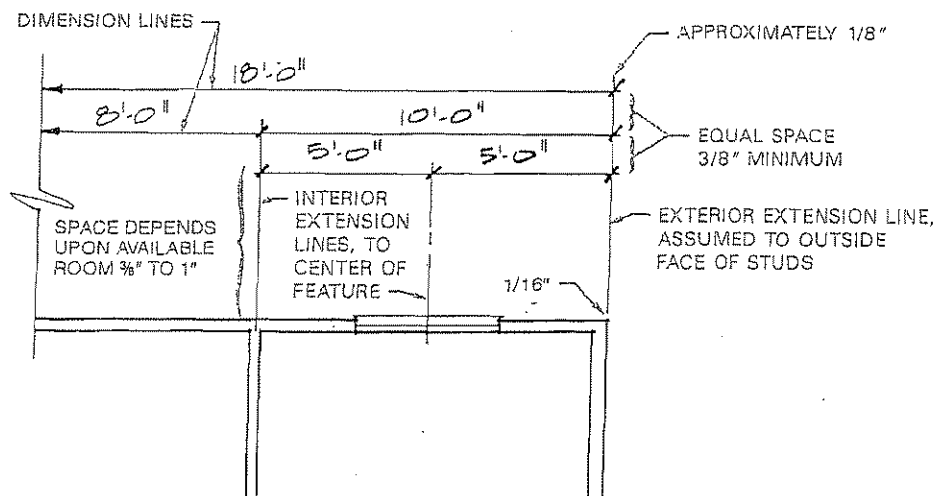

DIMENSION LINE SPACING

11. Room sizes may be shown by stating width and length.
12. When an area to be dimensioned is too small for the numerals, they are placed outside the extension lines.
13. Window and door sizes may be shown directly on the door or window symbol or may be indexed to a door or window schedule.
14. Curved leaders are sometimes used to eliminate confusion with other dimension lines.
15. When an area is too small for an arrowhead, dots may be used to indicate the dimension limits.
16. When the space is small, arrowheads may be placed outside the extension lines.
17. A dot with a leader refers to the large area noted.
18. Dimensions that cannot be seen on the floor plan or those too small to place on the object are placed on leaders for easier reading.
19. In dimensioning stairs, the number of risers is placed on a line with an arrow indicating the direction (up or down).
20. Windows, doors, pilasters, beams and areaways are dimensioned to their centerlines.
21. Use abbreviations when symbols do not show clearly what is intended.
22. Sub-dimensions **must** add up to overall dimensions ( $14'-0" + 12'-0" = 26'-0"$ ).
23. Architectural dimensions always refer to the actual size of the building regardless of the scale of the drawing.
24. Aligned dimensions are placed in alignment with an angled wall or feature.

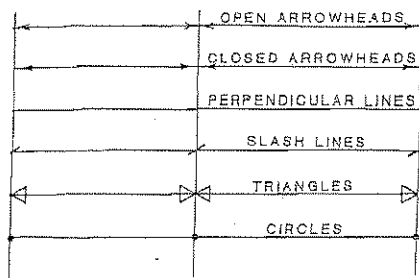

DIFFERENT STYLES OF  
ARROWHEADS

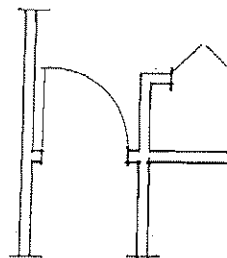

DOOR CENTERED  
IN HALLWAY, ASSUMED

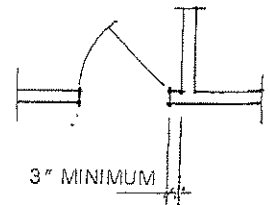

3" MINIMUM  
MINIMUM DISTANCE  
DOOR TO WALL ASSUMED

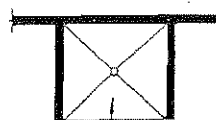

36" # SHOWER

LEADER LINE CURVED FREEHAND OR  
WITH IRREGULAR CURVE, OR STRAIGHT.  
CENTER AT BEGINNING OR END OF NOTE.  
TERMINATE WITH ARROWHEAD.

## COMMON SIZES OF ARCHITECTURAL FEATURES

1. Base cabinets generally are not dimensioned as they are typically 24" deep.
2. Closet poles are generally 15" from the back wall and are dashed lines.
3. Closet shelves are solid lines 12" from the back wall.

### 4. Room components:

- exterior walls: 6"
- exterior unheated walls (garage, shop): 4"
- Interior: 4"
- Interior plumbing wall (ie..toilet): 6"
- Hallway: 36" minimum wide
- entry hallways: 42 - 60"
- bedroom closets: 24" minimum depth; 48" length
- linen closets: 14-24" deep (not over 30")
- Washer/dryer space: 36" deep; 5'-6" long minimum
- Stairways: 36" minimum wide; 10.5" tread(typical); 11'-4" total run

### 5. Plumbing:

- Bathroom sink: 19" x 16" (oval); provide 9" from edge to wall and about 12" between two sinks; 36" minimum length
- Kitchen sink: 32" x 21" for a double, 42" x 21" for a triple
- Laundry sink: 21" x 21"
- Shower: 36" square; 42" square; or a combination of 36", 42", 48" and 60" for fiberglass; any size for ceramic tile
- Toilet space: 30" wide (minimum), 24" clearance in front
- Washer/Dryer: 2'-4" square (approximately)

### 6. Appliances:

- Forced air unit: gas- 18" square (minimum) with 6" space all around (can NOT go under the stairs) ; electric- 24" x 30" (same space requirements as gas)
- Water heater: gas- 18-24" diameter (can NOT go under the stairs)
- Refrigerator: 36" wide space; approximately 27-30" deep; 4" from wall, 4" from the base cabinet.
- Stove/cooktop: 30" x 21" deep
- Built-in oven: 27" x 24" deep
- Dishwasher: 24" x 24"
- Trash compactor: 15" x 24" deep; near sink, away from stove
- Broom/pantry: 12" minimum x 24" deep, increasing by 3" increments
- Desk: 30" x 24" deep (minimum); not within the work triangle
- Built-in vacuum: 24" x 30" diameter

### 7. Doors:

- Entry: 36" x 6'-8"; 42" x 8'-0"
- Slider or French: 5', 6', 8' (double); 9', 10' (triple); 12' (four panel)
- Garage, utility, kitchen and bedrooms on custom houses: 2'-8"
- Bedrooms and bathrooms of nice homes: 2'-6"
- Bathroom closets: 2'-4"
- Garage: 8' x 7', 9' x 8', 16' x 7' and 18' x 7'

## 8. Windows:

- Living, family: 8' - 10'
- Dining: 6' - 8'
- Bedrooms: 4' - 6'
- Kitchens: 3' - 5'
- Bathrooms: 2' - 3'
- Sliding: 4', 5', 6', 8', 10', 12'
- Single hung: 24", 30", 36", 42"
- Casement: same as sliding
- Fixed awning: 24", 30", 36", 42", 48"
- Fixed sliding: 24", 30", 36", 42", 48"
- Picture: 4', 5', 6', 8'
- Bay: 8' - 10' total; sides - 18-24" wide

## SOME METHODS OF DIMENSIONING FLOOR PLANS

\* Method B is preferred for this class (deviation will require teacher approval)

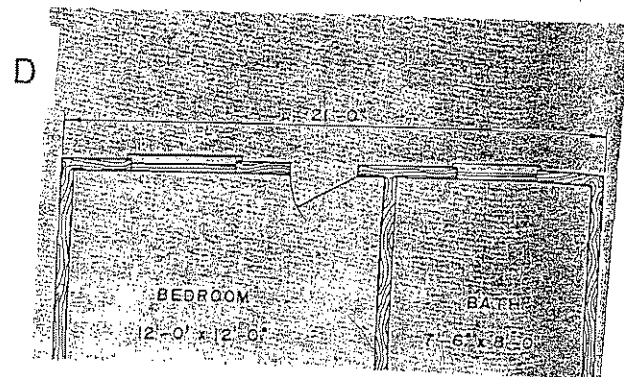
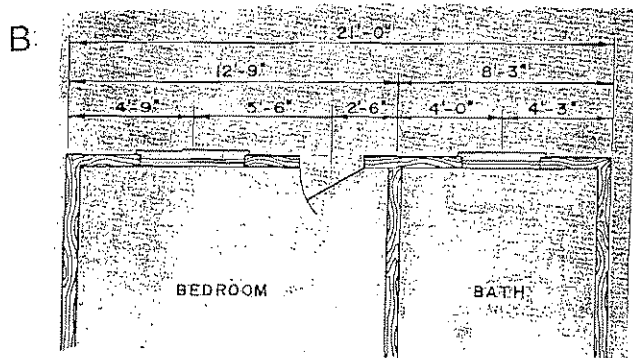
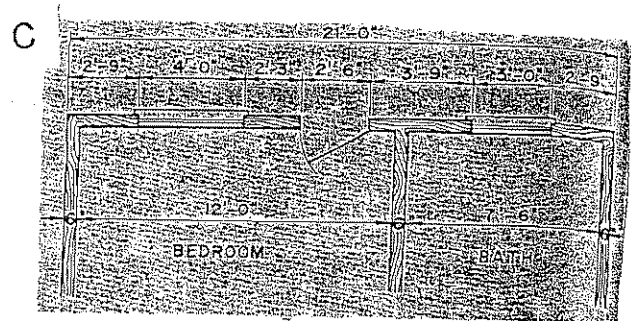
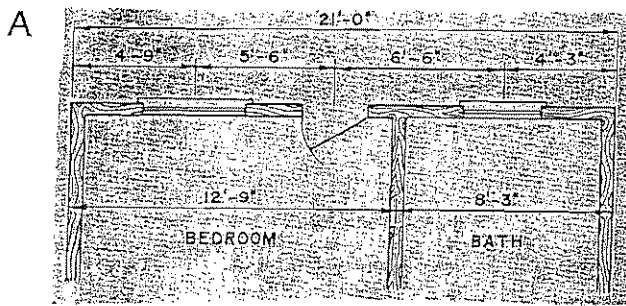

\*In summary, a floor plan must be completely dimensioned to ensure that the house will be constructed precisely as designed. Many construction mistakes result from errors in architectural drawing, and most of those errors are in dimensioning! One of the best ways to learn how experienced drafters lay out dimensions is to study and evaluate existing plans.

NAME \_\_\_\_\_

ARCHITECTURAL DRAWING  
WORKSHEET: MEASUREMENT

# MEASURING A FLOOR PLAN

MAKE ALL MEASUREMENTS WITH SCALE: 1/4"=1'-0".  
SUB DIMENSIONS MUST TOTAL CORRECTLY.

